

A-A 1:2

B 1:1

Ribs are made of 10mm height H60 foam

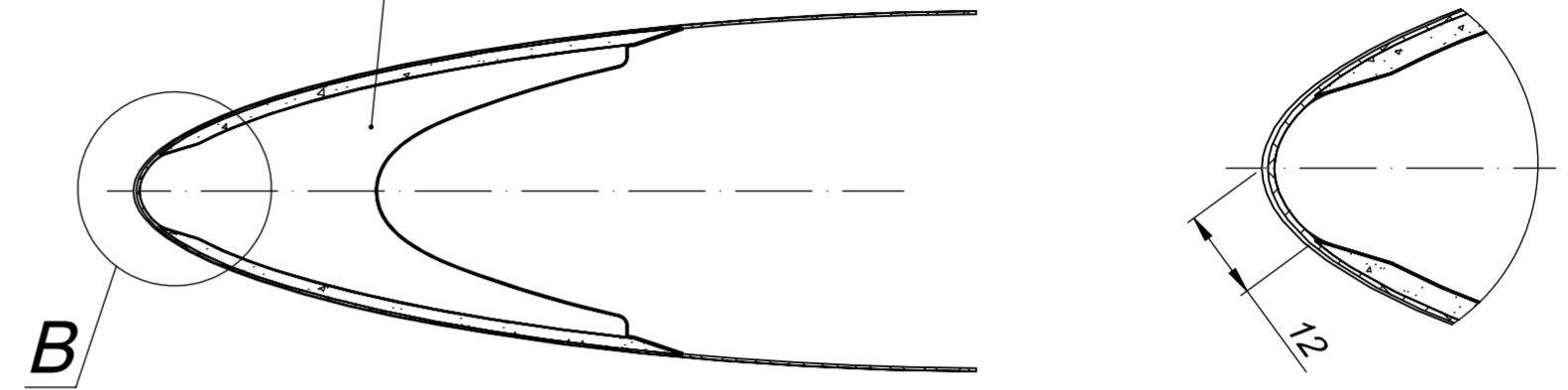

Fibre layup for the fin shell:

- Outer layers:
1. One layer of 90070 fabric +45° angle.
 2. One layer of 92110 fabric -45° angle.
 3. One layer of 92125 fabric +45° angle.
 4. 3mm height H60 foam
- Inner layers:
5. One layer of 92110 fabric -45° angle.

1. * Reference dimensions.
2. H14, h14 ± IT14/2.
3. Dimensions not shown in drawing defined by mould.
4. Use epoxy resin L285 and hardener H287.
5. Use glues: L285 + H287 + 7% CAB-O-SIL.
6. Use LAVSAN fabric to prepare the gluing zones.
7. Moulding and gluing works quality must be checked using the typical moulding technology for products from epoxy resin L20.

| Technical note No.3 | | | |
|---------------------|------|----------------|-------------------------|
| Ch. | Pag. | Doc. Nr. | Signature Date |
| Done | | A.Abromavičius | |
| Checked | | J. Kliūnas | |
| N. contr. | | D. Juočienė | |
| Approved | | K. Juočas | |
| Fin shell scheme | | | Litera Weight Scale |
| | | | 0 527.07 1:4 |
| | | | Page 2 Pages 3 |
| | | | Sportinė Aviacija ir Ko |
| | | | Format A2 |

C 1:2

1:5

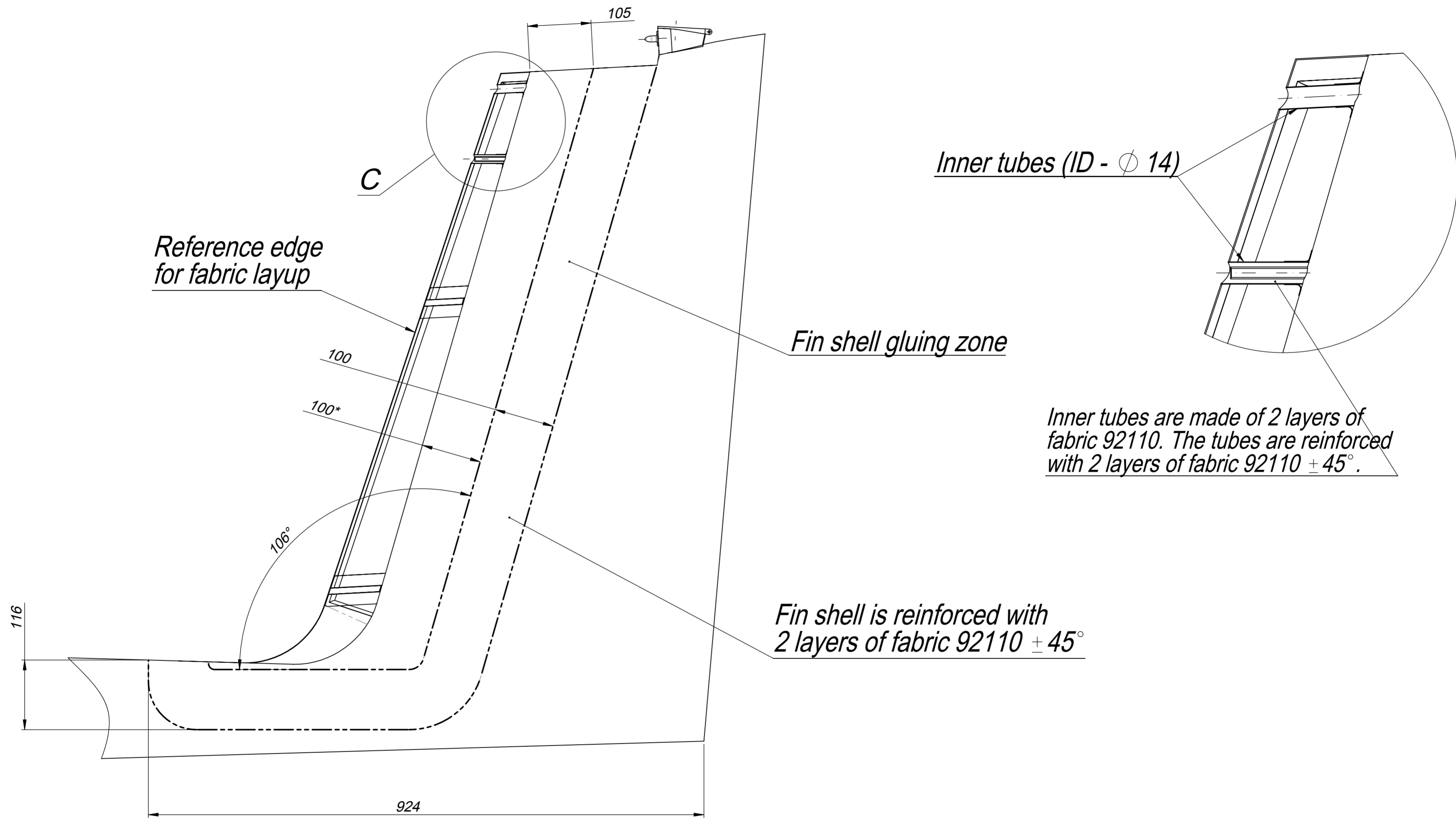

Inner tubes (ID - ϕ 14)

Fin shell gluing zone

Inner tubes are made of 2 layers of fabric 92110. The tubes are reinforced with 2 layers of fabric 92110 \pm 45°.

Fin shell is reinforced with 2 layers of fabric 92110 \pm 45°

| Ch. | Pag. | Doc. Nr. | Signature | Date |
|-----|------|----------|-----------|------|
| | | | | |