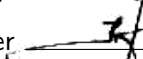

	<h2>Service bulletin</h2>	Doc. No. 019.23.001
		Revision 1
		Date: 2023-06-22
"SA ir Ko" EASA.AP160	<b>Airbrake blades inspection and modification</b>	Page 1 of 4

- Subject:** Inspection of the lower airbrake blades bushings and replacement of washers.
- Applicability:** LAK-19, LAK-19T  
TCDS No. EASA.A.012, issue 03, date of issue 16/10/2006, all serial numbers.
- Urgency:** This bulletin must be accomplished within 90 days after publication.
- Reason:** In case of glue failure, the lower blade of the airbrake may be pushed out of the fixing screw due to air pressure (Figure 1). The washer with bigger outside diameter (Figure 2b) would prevent the blade from separating from its supporting structure.
- Actions:**
1. Inspection. Remove the lower airbrake blades (see *Instruction 1*) and check all the bushings of the blades. Look around the metal parts for cracks and splits in plastics.  
If the damage is found, report to sailplane manufacturer.
  2. Repair. If cracks or splits in plastics are found, these shall be repaired in accordance with instructions obtained from the sailplane manufacturer.
  3. Modification. Reassemble using different type washers (see *Instruction 1*).
- Weight and Balance:** Accomplishment of this bulletin does not affect the C.G. of the sailplane. A new weight and C.G. determination is not necessary.
- Release to Service:** Inspection, repair and modification shall be done by the certified staff.
- Approval:** The technical information contained in this Service Bulletin has been approved by EASA with approval number 10085497

2023-06-22	Pociūnai, Prienai, Lithuania	JSC "Sportinė aviacija ir KO" Chief Designer  /K. Juočas
------------	------------------------------	--

	<b>Service bulletin</b>	Doc. No. 019.23.001
		Revision 1
		Date: 2023-06-22
"SA ir Ko" EASA.AP160	<b>Airbrake blades inspection and modification</b>	Page 2 of 4

**Figure 1:** Lower blade separation scheme

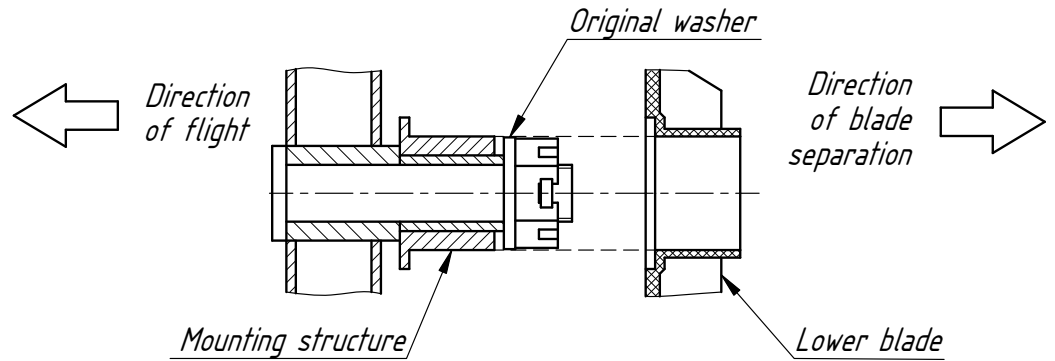

**Figure 2:** Original and modified design of the lower blade mounting points

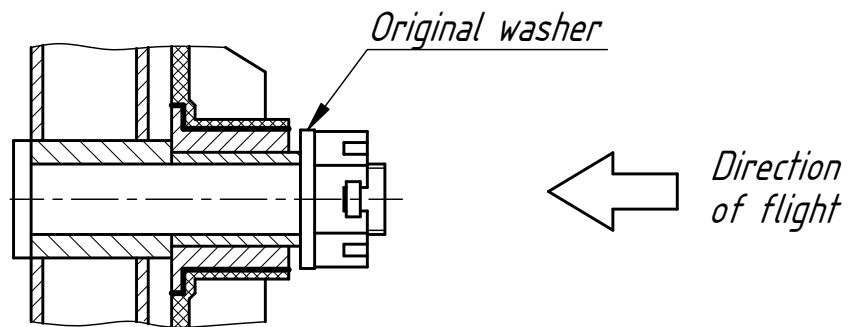

**(a)** Original version (with small washer)

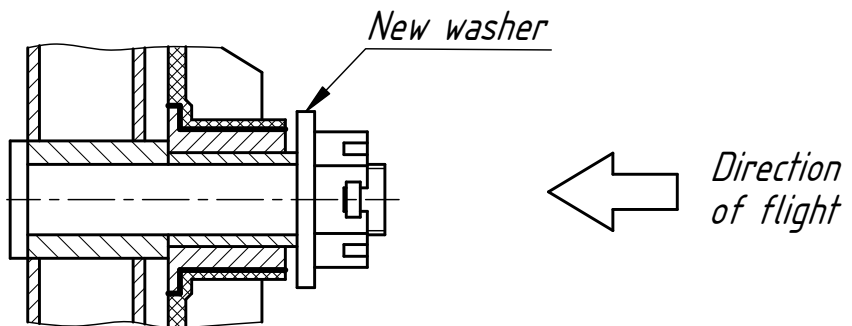

**(b)** Modified version (with bigger washer)

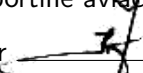
2023-06-22	Pociūnai, Prienai, Lithuania	JSC "Sportinė aviacija ir KO" Chief Designer  /K. Juočas
------------	------------------------------	--

**Instruction 1:** Airbrake blades inspection and modification:

1. Remove the split pins (pos.1), unscrew the nuts (pos.2), and remove the washers (pos.3);
2. Remove the lower airbrake blades (pos.4) and check all the bushings (pos.5). Look around the metal parts for cracks and splits in plastics.
3. After inspection (and repair, if needed), reassemble using different type washers and new split pins (see *Parts List*).

**Warning:** Do not use the original washers.

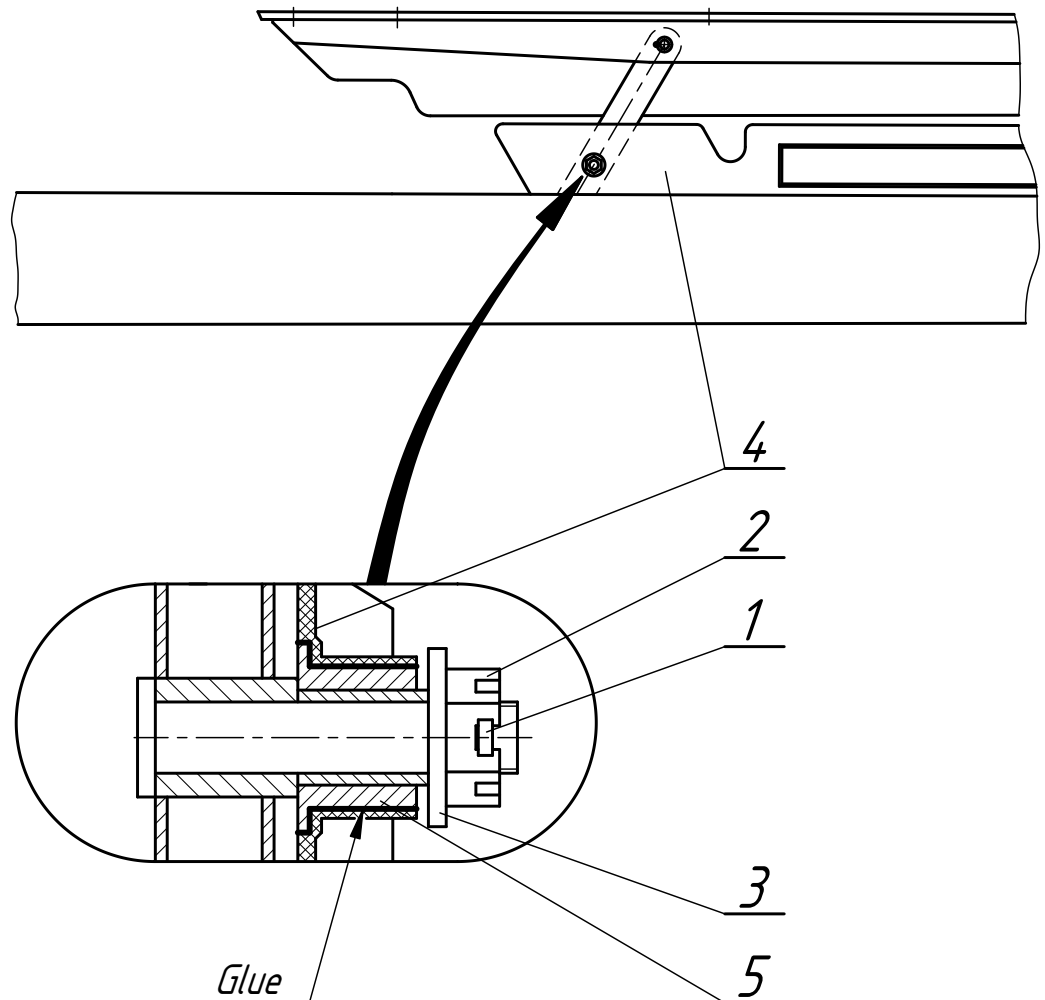

(continued on the next page)

	<h1>Service bulletin</h1>	Doc. No. 019.23.001
		Revision 1
		Date: 2023-06-22
"SA ir Ko" EASA.AP160	<b>Airbrake blades inspection and modification</b>	Page 4 of 4

**Instruction 1:**  
(continued)

PARTS LIST

ITEM NO.	DESCRIPTION	QTY
A03-01	Washer DIN 522 A6.4x15x1.5 Znp	4
A03-02	Split pin DIN 94 1.6x16 Znp	4

2023-06-22	Pociūnai, Prienai, Lithuania	JSC "Sportinė aviacija ir KO" Chief Designer  /K. Juočas
------------	------------------------------	--